

**AA-82161-C Floor Mat  
dual high shift pedal holes**

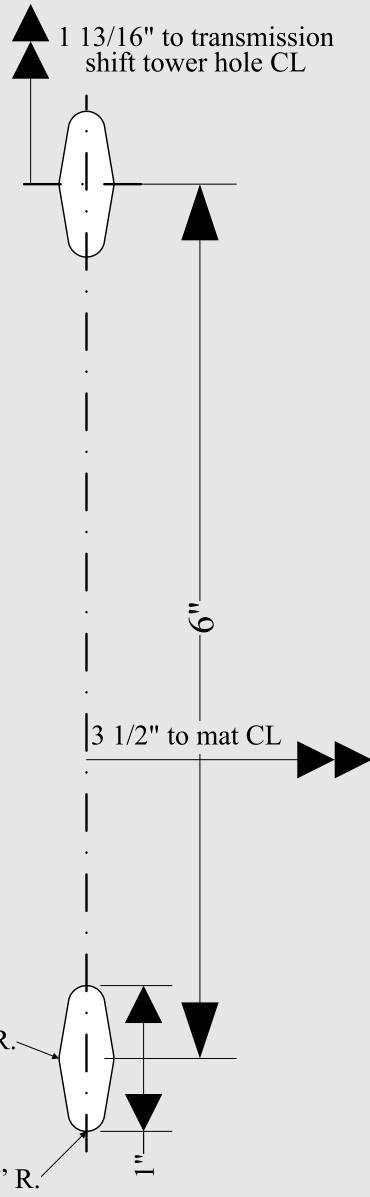

**AA-82161-C & A-25230-C Floor Mat  
3-Speed Transmission Tower & Hand Brake Lever Holes**

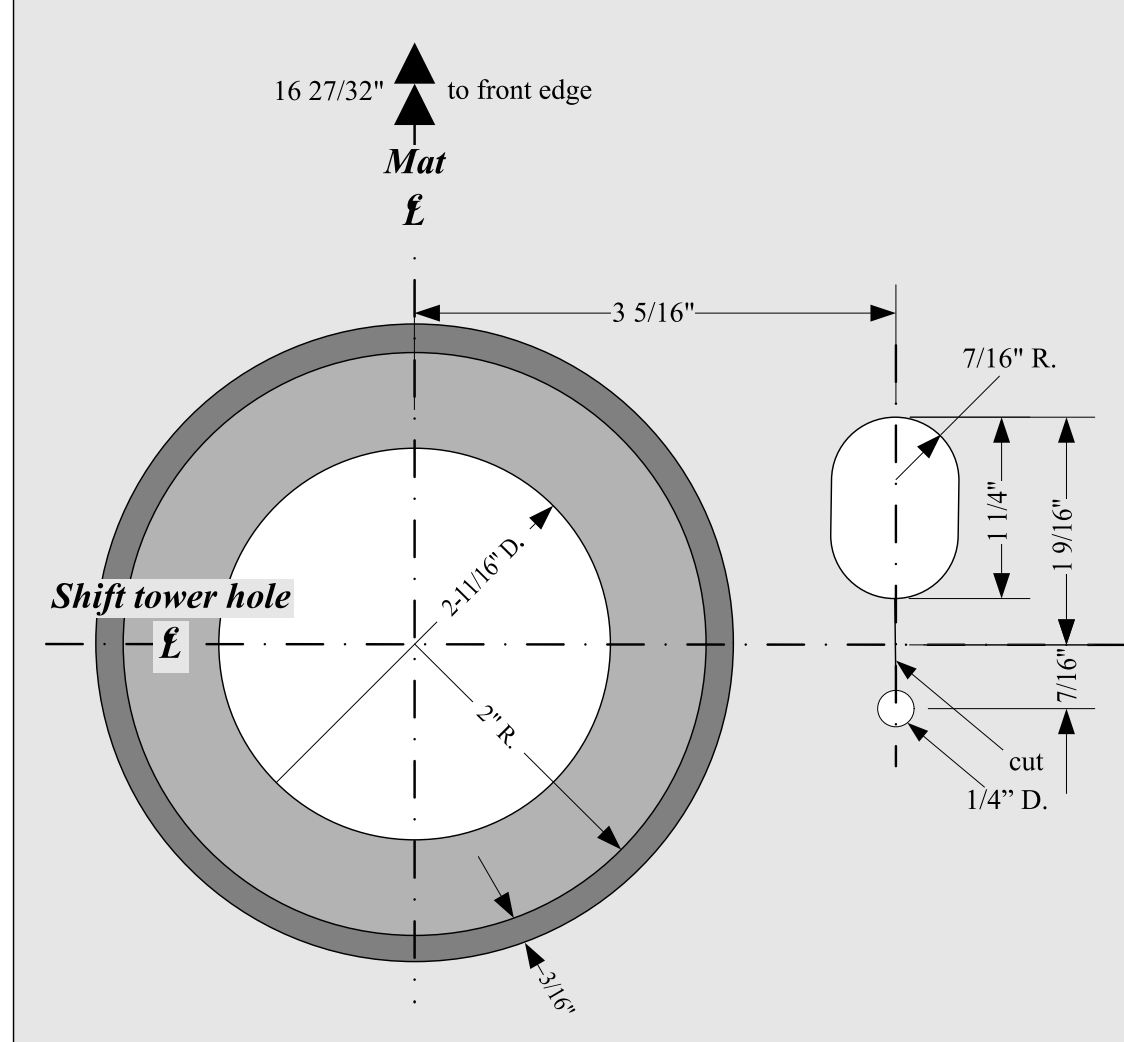

**AA-82161-C & A-35230-C Floor Mat  
accelerator & foot rest holes**

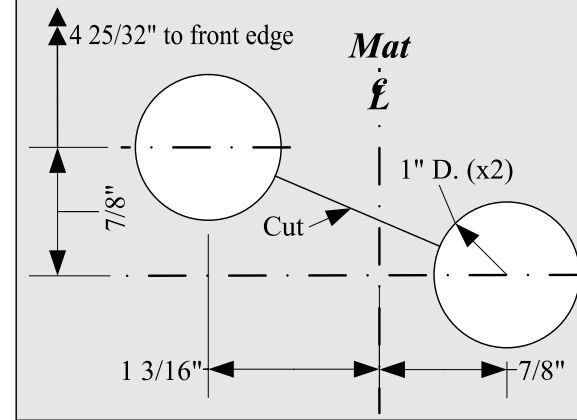

**Section AA**

